

Cashmaster **one** **pro** **plus** **max**®

Cashmaster
printer one

User Guide

Document information

Date: November 6th, 2024

Document ID: 10503E

Contact

Cashmaster USA, Inc
9665 Tradeport Drive
Orlando
Florida
32827
USA

www.cashmaster.com
enquiriesusa@cashmaster.com

Copyright

Copyright © 2024 Cashmaster International Ltd - All Rights Reserved.

Other product and company names may be trademarks or registered trademarks of other companies, and are the property of their owners. They are used only for explanation, without intent to infringe.

Intended purpose

This document is provided for Cashmaster One users and describes how to get the most from their Cashmaster One product.

Safety and using the counter



The counter must be used on a stable and level surface.



The counter cannot be used with excessive vibration.

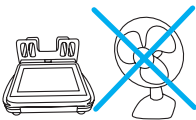

The counter cannot be used when exposed to strong air-conditioning systems or excessive drafts.



Warning

This is a class A product. In a domestic environment, this product may cause radio interference. In this case, the user must take adequate measures.

FCC statement

This device complies with Part 15 of the FCC Rules. Operation is subject to the following conditions:

- This device may not cause harmful interference.
- This device must accept any interference received, including interference that may cause undesired operation.

This equipment has been tested and found to comply with the limits for a Class A digital device, pursuant to Part 15 of the FCC Rules.

These limits are designed to provide reasonable protection against harmful interference when the equipment is operated in a commercial environment. This equipment generates, uses and can radiate radio frequency energy, and if it is not installed and used in accordance with the instruction manual, it may cause harmful interference to radio communications. Operation of this equipment in a residential area is likely to cause harmful interference, in which case the user will be required to correct the interference at their own expense.

Any modifications made to this device that are not approved by Cashmaster International Ltd may void the authority granted to the user by the FCC to operate this equipment.

Contents

1 Product information	8
1.1 Variants	8
1.2 Connections	13
1.3 Power	13
2 Getting started	15
2.1 Package contents	16
2.2 Install the hod	18
2.3 Install the optional printer	18
2.4 Connect the power adaptor	20
2.5 Power up	21
3 Interface	22
3.1 Count screen	23
3.2 Quick Action Menu	28
3.3 Power Key Menu	29
4 Operations	30
4.1 Counting	30
4.2 System settings	34
4.3 Editing the counter workflow	36
4.4 Recalibrating container, packaging and non-cash items	36
4.5 Stored Counts (Max Only)	37
4.6 Changing the printer roll	37
4.7 Removing the hod	39
4.8 Care and maintenance	40
4.9 Re-setting your device	40
5 Troubleshooting	41
5.1 Bills	41
5.2 Coins	42
5.3 Printer	42
5.4 Bill learning	43

5.5 Miscellaneous43

6 Specifications45

6.1 Regulatory and approvals45

6.2 Counter specifications45

6.3 Printer specifications46

7 Global support47

1 Product information

The Cashmaster One product range counts bills, coins and coupons in any configured currency, and can help streamline cash-handling business processes.

The Cashmaster One counters are count-by-weight devices operated via a robust colour touch-screen display.

All Cashmaster One counters are compatible with the Cashmaster Printer One.

All models support easy software updates using a USB flash drive.

1.1 Variants

The Cashmaster One product range has three variants:

- **Cashmaster One Pro**
Counts bills and coins in up to two different currencies.
- **Cashmaster One Plus**
Counts bills, coins, vouchers and coupons. On-screen numeric keypad for manual entry of non-cash items such as debit or credit cards, and add-list for checks, in up to four different currencies.
- **Cashmaster One Max**
Counts bills, coins, vouchers and coupons. On-screen numeric keypad for manual entry of non-cash items such as debit or credit cards, and add-list for checks, in up to eight different currencies. Multi-till feature to save and recall hundreds of individual till count records for later retrieval and download. Ethernet connectivity as standard.

1.1.1 Cashmaster One Pro

The Cashmaster One Pro accurately counts loose and strapped cash, and is ideal for small businesses with one till.

The Cashmaster One Pro has the following features:

- Quickly counts coins and bills
- Counts up to two different currencies
- User-configurable float / Start bank feature
- High quality 4.3" (11cm) colour touch-screen with anti-glare coating and robust toughened glass
- Compatible with the optional Cashmaster Printer One
- Integrated help function
- Serial and USB connectivity
- Built-in calculator app



1.1.2 Cashmaster One Plus

The Cashmaster One Plus performs all cash-counting requirements including vouchers and coupons, and non-cash items such as debit or credit cards and checks.

With multiple count mode capabilities, the Cashmaster One Plus is ideal for small to medium-sized businesses with multiple tills.

The Cashmaster One Plus has the following features:

- On-screen alpha-numeric keypad for count ID entry
- Counts up to four different currencies
- Supports up to four count modes
- High quality 5.0" (12.7cm) touch-screen display with anti-glare coating and robust toughened glass
- Compatible with the optional Cashmaster Printer One
- Integrated help function
- Serial and USB connectivity
- Built-in calculator app



1.1.3 Cashmaster One Max

The Cashmaster One Max offers advanced functionality, including multi-till memory and built-in Ethernet. With extended features and customization options, the Cashmaster One Max is ideal for larger organizations, or businesses which have demanding processes and complex operational requirements.

The Cashmaster One Max has the following features:

- On-screen alpha-numeric keypad for count ID entry
- Counts up to eight different currencies
- 10+ customised count modes
- Multi-till memory - save and recall hundreds of individual till counts
- Ethernet connectivity enables remote management from a central location
- High quality 5.0" (12.7cm) touch-screen display with anti-glare coating and robust toughened glass
- Compatible with the optional Cashmaster Printer One
- Integrated help function
- Serial and USB connectivity
- Built-in calculator app



1.1.4 Cashmaster Printer One

The optional Cashmaster Printer One can integrate with any of the three counters in the Cashmaster One range. It easily and neatly fits into the base of the counter. With intelligent autostart, as soon as the printer is installed it is ready for use - no setup is required. The Cashmaster Printer One can print graphics in addition to text, providing additional flexibility and output options.

The Cashmaster Printer One has the following features:

- Ink-free thermal printing
- Integrated printer - no additional desk space required
- No cables or leads to connect
- Instant and quiet operation
- Charges through the Cashmaster One counter
- Energy efficient





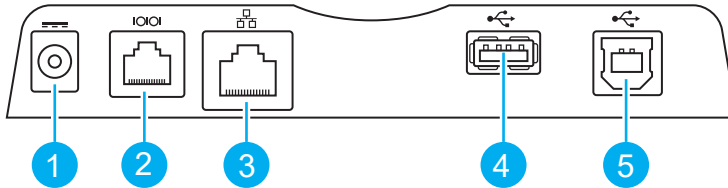

1.2 Connections



Warning

Communication ports should only be directly connected to equipment within the same building.

Item		Description
1		12V DC Power adaptor port
2		Dual-use RS232/Serial IO port
3		10/100 Ethernet port Only available on Cashmaster One Max.
4		USB Host port - Type A
5		USB Device port - Type B

1.3 Power

Power is provided using the 12V DC power adaptor.



Warning

Only use a Cashmaster-supplied power adaptor with your Cashmaster One product. Using a non-Cashmaster power adaptor may result in damage to the product and will invalidate your warranty. Use only with original equipment manufacturers batteries. Do not attempt to install third-party batteries in this equipment.



Warning

No user serviceable parts inside. Do not disassemble - risk of electric shock.
Do not disassemble battery pack - risk of chemical leak.
For indoor use only. Do not charge unattended.
Do not connect power adaptor with wet hands or use a damaged or wet power adaptor.

1.3.1 Battery

The Cashmaster One counter battery is charging when the AC power is connected .

Typical charging time is 6 hours. For best results, charge at between 10°C/50°F and 30°C/86°F.

A fully-charged battery lasts for up to 8 hours with normal use.

The Cashmaster One scale will operate as normal if the unit is connected to the AC power, even if the battery is flat.

1.3.2 Printer Battery

The Cashmaster One printer battery will automatically charge when installed in the scale and the scale is connected to the AC power.

Cashmaster One printer requires battery power to operate and will not work when the battery is flat.

2 Getting started

This section describes the initial steps required to start using the Cashmaster One counter.

2.1 Package contents

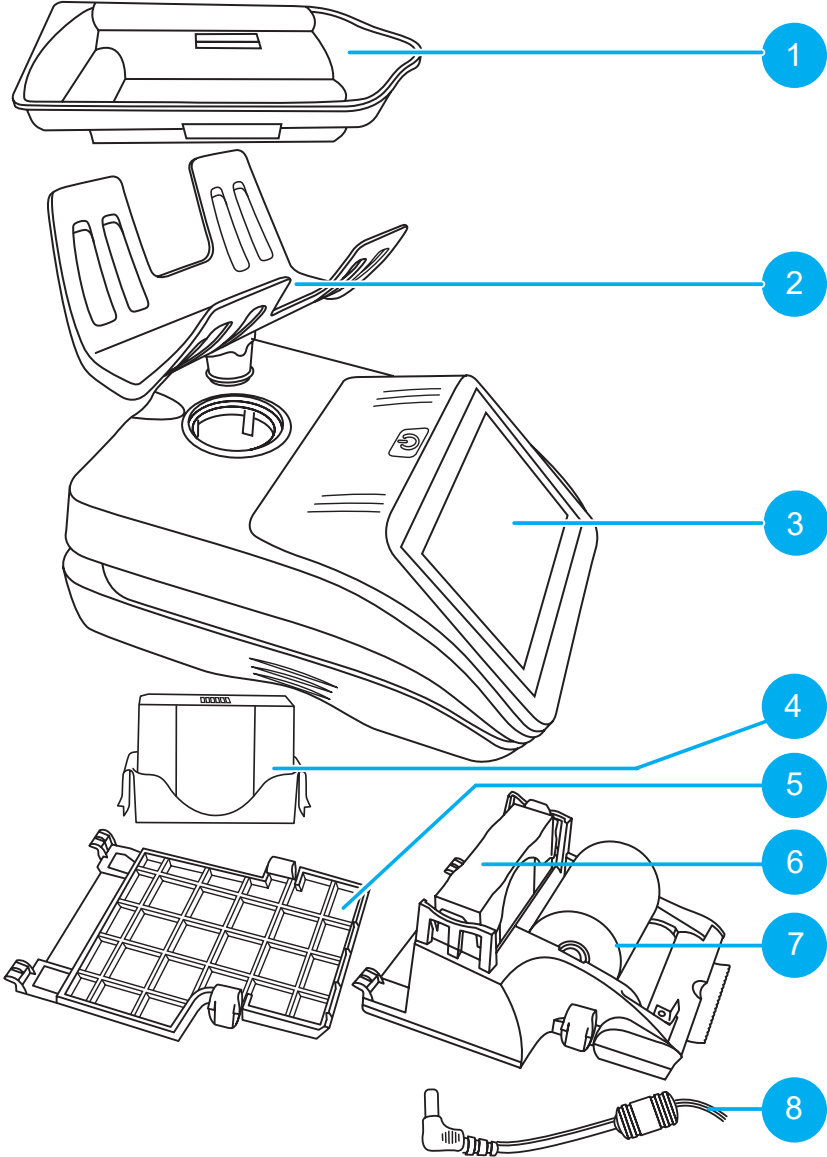

2.1.1 Package contents list

Standard Items

Item	Description
2	Hod
3	Cashmaster One
5	Base plate cover
8	Power adaptor

Optional Items

Item	Description
1	Scoop
4	Cashmaster One scale battery
6	Cashmaster Printer One with battery
7	Paper roll

2.2 Install the hod

1. Place the counter on a stable, level surface.
2. Insert the hod into the counter and gently twist and push down until it clicks into position.

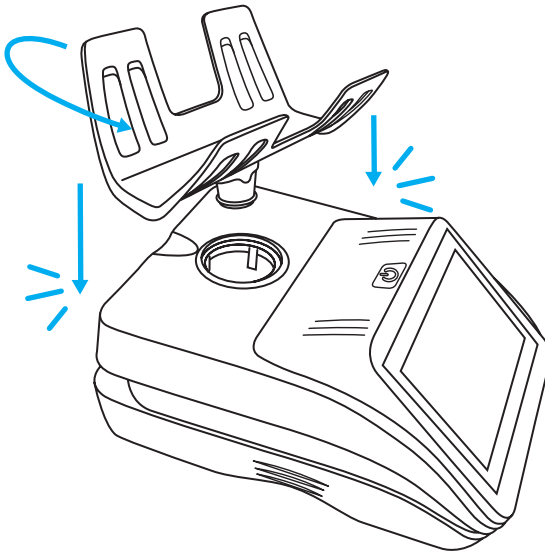

2.3 Install the optional printer

The Cashmaster Printer One can be integrated into the base of all Cashmaster One counters.

1. Carefully turn over the counter.
2. Remove the base plate cover by pressing both retaining tabs and pulling the base plate down and forward, towards the front of the counter.

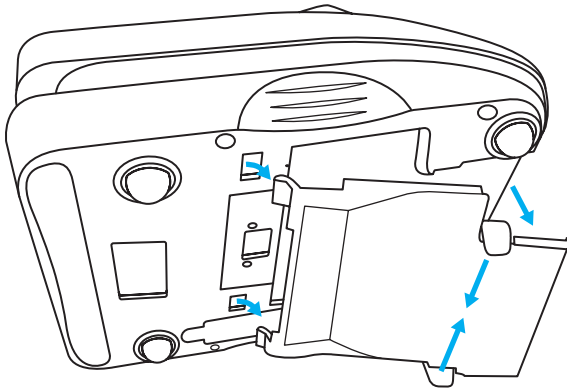

3. Carefully insert the two holding tabs on the printer into the base of the counter.
4. Lift the printer up and into the base of the counter.
5. Push the printer into the counter until you hear the click of the printer's retaining tabs.
6. Ensure that both tabs are fully in place.

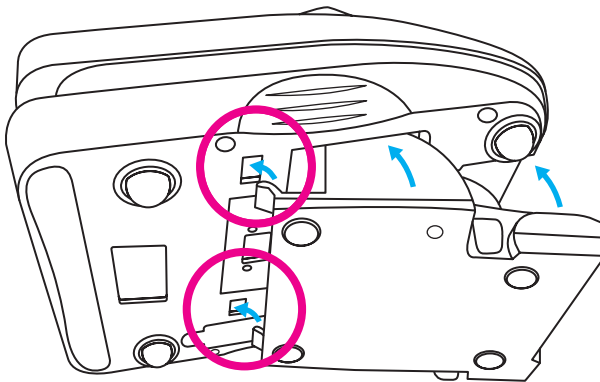

After you have inserted the printer and powered up the counter, the printer icon is shown in the status bar .

2.4 Connect the power adaptor

1. Insert the power adaptor mains plug into an AC power outlet.
2. Insert the power adaptor plug into the counter power adaptor port.
3. Please ensure the scale is charged for a minimum of 6 hours before use.

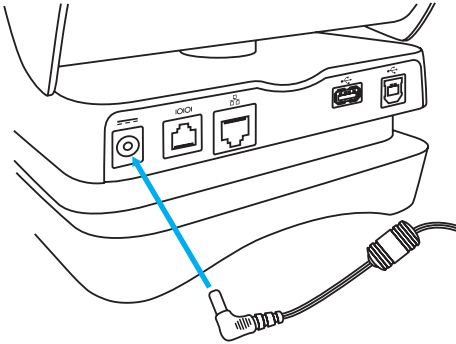

The Cashmaster One counter is designed for portable use and has an eight-hour battery life.

2.5 Power up

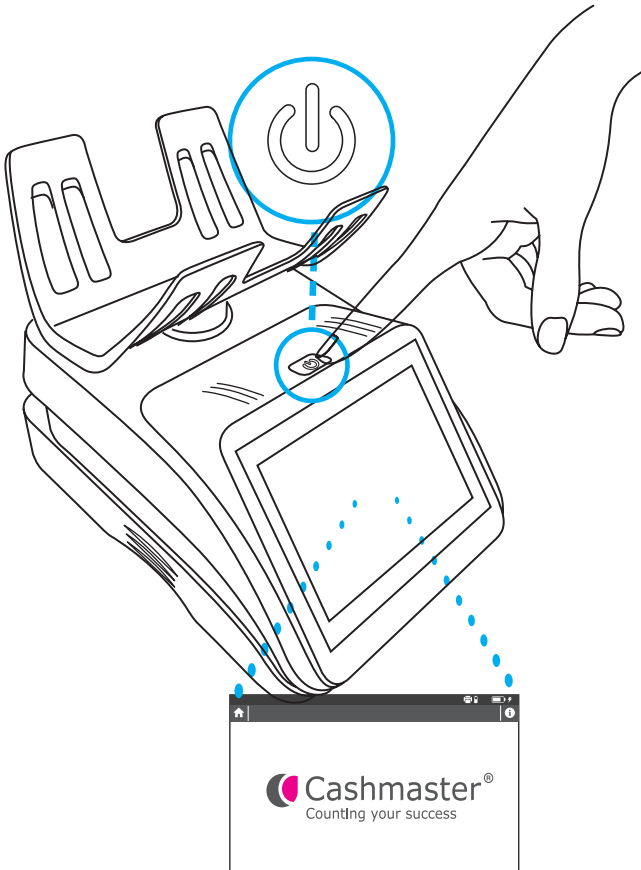

Press the power button to start the Cashmaster One counter.

3 Interface

All variants of the Cashmaster One range have a touch-screen interface which is used to perform count and setup tasks on the counter.

When the counter is powered up, a start-up screen is briefly shown followed by the **Home** screen for the variant of your counter. Please note that the Cashmaster One Pro will go straight to the count screen.

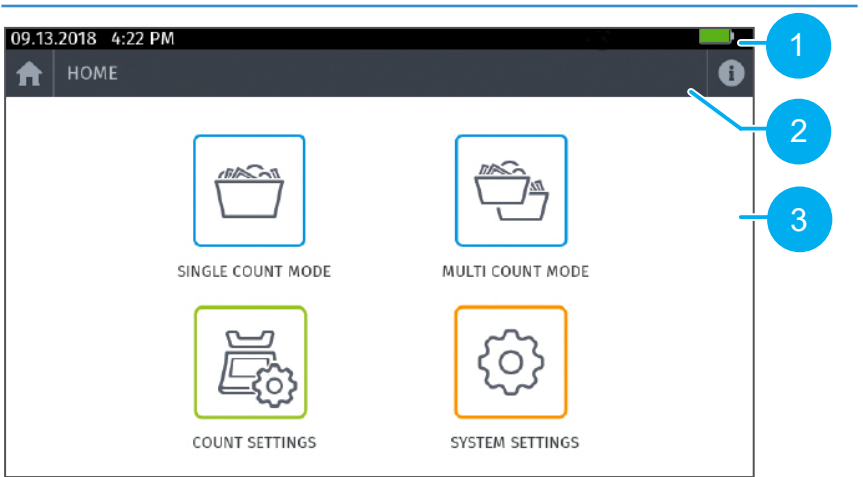

Figure 1 - Cashmaster One Max Home screen



Item	Description
1	Status bar
2	Help, Home and Workflow control icons
3	Count and settings icons

The **Home** screen has several common features across all counter variants:

- The **Status bar** is visible at the top of the interface, displaying time and date information, and various icons that provide battery level, charging, connectivity and peripheral status information.

- Tap  to return to the **Home** screen.
- Tap  to get Customer Service contact information.

3.1 Count screen





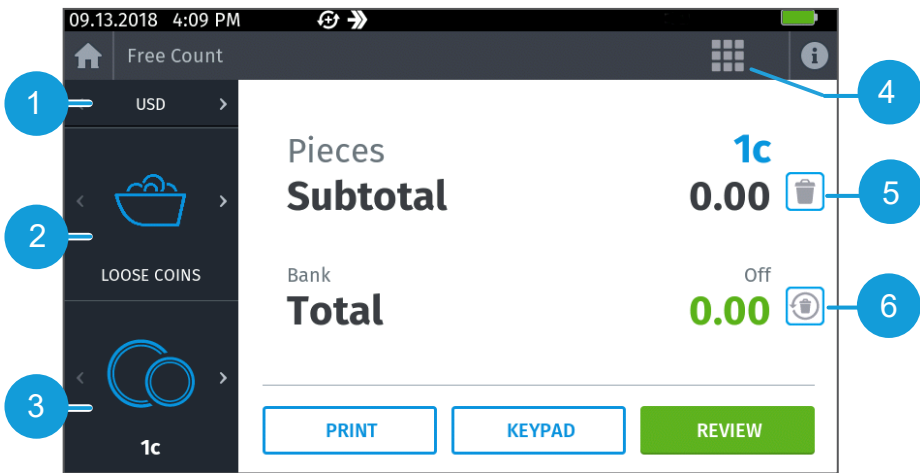



Each variant has one or more **Count** screens containing additional controls and information for the counting workflow.





Figure 2 - Cashmaster One Plus/Max Count screen













Item	Description
1	Selected currency
2	Media type
3	Selected denomination
4	Quick action menu
5	Clear subtotal
6	Clear and restart





- Tap  to toggle information highlighting the Count screen user interface. Selecting a highlighted area displays additional information.



Status bar icon	Description
	Workflow auto-add
	Workflow auto-advance
	Cashmaster Printer One is installed
	Network
	USB device mode Counter is connected to USB host
	USB Flash drive inserted
	Battery level indicator
	AC power connected and battery charging

Count and settings icon	Description
	Single till count mode(s)
	Multi-till count mode(s)
	Count settings
	System settings

Media icon	Description
	Loose coins - scoop as coin container
	Loose coins - weighable till cups as coin container
	Rolls of coins

Media icon	Description
	Bags of coins
	Manual entry - Keypad entry for non-physical cash items, such as debit and credit card values.
	Loose bills and tokens
	Add lists - keypad entry for itemised cash items such as checks or vouchers.
	Packaged bills
	Rolls of tokens
	Bags of tokens

Denomination icon	Description
	Bills, for example, \$1, \$10, \$50.
	Coupons
	Checks
	Cards
	Coins, for example, 1c, 10c.

Notification icon	Description
	Counter error
	Changes made

3.2 Quick Action Menu

The Quick Action Menu allows you to access functions quickly such as Auto Advance, Auto Add, and access the float/start bank settings. Please note that the functions in the Quick Start Menu will vary depending on your software configuration.

Figure 3 - Quick Action Menu screen

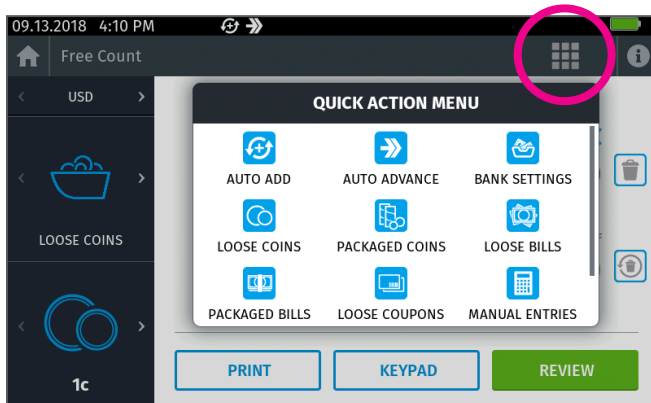



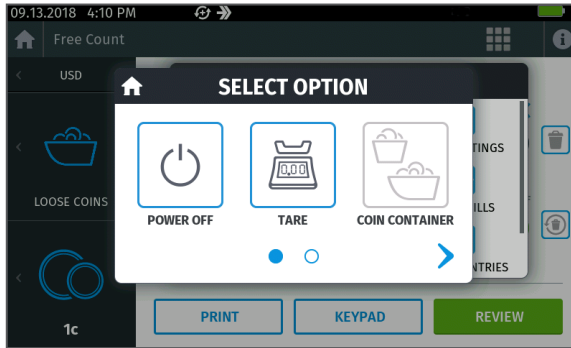

3.3 Power Key Menu

Tap the Power Key at any time to display a pop-up menu screen.

Figure 4 - Power Key Menu screen



Power key menu icon	Description
	Power off - Tap to power off the device.
	Manual tare - Manually reset the current zero weight value.
	Coin container - Calibrate an alternative coin container. Only available from the Count screen.
	Snapshot - Captures a bitmap image of the current display and saves to an attached USB flash drive.
	Calculator - Opens the built-in calculator app.

4 Operations

This section describes common tasks required for the operation of the Cashmaster One counter.

4.1 Counting

The Cashmaster One counters weigh and count coins, bills and coupons in sets of a single denomination. A running total is kept at all times.

A cash-count workflow typically begins with counting loose coins. Therefore, at the beginning of a count, the Cashmaster One device may request an empty coin container such as the Cashmaster scoop or an empty, weighable till cup from your cash drawer.

The Cashmaster One counters can remember the weight of your preferred coin container so that it does not need to be re-weighed each time you begin a count. To do this, tap to select the **Save container weight** checkbox on the **Calibrate coin container** pop-up.

Figure 5 - Calibrate coin container pop-up

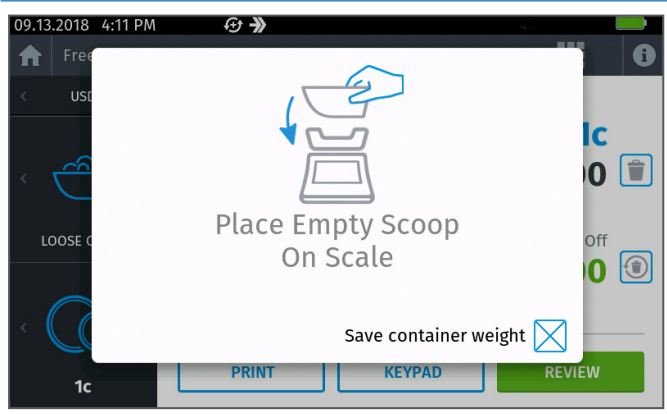



You can quickly calibrate an alternative coin container using the Power Key Menu option **Coin Container**.

► For more information, see Section 3.3 Power Key Menu.

4.1.1 Count modes

A **cash count** is the process of counting cash using a Cashmaster One device. The Cashmaster One Plus and Max models allow you to configure multiple '**cash count modes**'. A **count mode** is comprised of the following configurable settings:





- Count mode name
For example, **Free Count** or **Till Count**
- Workflow
- Input ID requirements
For example, **Till number**
- Float/bank settings
- Printer output options
For example, **No signature lines**, **Cashier signature** or **Manager signature**
- Storage and memory options
Whether or not the count is stored (Max only)





Count mode names are descriptive only, and do not affect the way in which a count mode functions.





The **workflow** describes the items you wish to count within the count mode, and the order in which you wish to count them.

For example, your defined **workflow** might involve weighing cash in the following order:

Action	Description
	Loose coins (Cups)
	Coin rolls
	Loose bills
	Manual entries

4.1.2 Cash-count workflow







Action	Description
	From the Home screen, tap the required count type. (Single Count / Multi Count).
	Place the empty coin container on the counter hod. The counter adjusts for the Tare weight of the coin container.





Action	Description
	<p>Fill the coin container with the requested media and place on the counter hod.</p>
	<p>The counter workspace updates with the counted media.</p>
	<p>Remove the coin container.</p>
	<p>If auto-advance is enabled, the workflow automatically moves onto the next media type to be counted. If auto-advance is not enabled, manually select the next media and denomination. Repeat this process until you reach the end of the workflow.</p>
	<p>Some media types may require manual entry of count information using the keypad.</p>
<p>To review your count, tap Review. The Review screen is displayed. From the Review screen you can review, print and transfer your count. Tap Finish to exit the count.</p>	







Bills are counted in 'slices' of up to 30 bills at a time. If too many bills are added, or if the counter cannot determine the quantity of bills on the hod, the counter prompts you to remove a few bills at a time until it can successfully count the slice.



4.2 System settings

Setting	Description	Purpose
	Display / Audio	Adjust display brightness and volume of the device.
	Language settings	Select the language used on the display of the counter.
	Date and time settings	Adjust the date and time of the device.
	Printer settings	Adjust the printer hardware settings, and configure the print layout including packaged media subtotals, and cashier/manager approval fields.
	Select grams mode	Activate weighing mode which can be used for weighing items, or checking the accuracy of the internal measurement system.
	Diagnostics	Perform diagnostic checks on the internal hardware. For troubleshooting / customer support purposes only.
	Advanced settings	Adjust advanced settings for the device, including device calibration, currency settings and advanced comms settings. Contact customer support if access is required. Changes may affect the accuracy of the device.

Setting	Description	Purpose
	About	Display status information about the hardware and software installed in the counter and printer (if connected).
	System update	To update counter & printer software, from an installed USB flash drive.
	Switches	Device settings which can alter preferences related to counting operations, such as count ID parameters and the counting sequence (Depending on the model).
	Environment test	A diagnostic tool to check the stability of the environment in which the device is installed.

4.2.1 Advanced settings

Setting	Description	Purpose
	Calibrate	Perform calibration of the internal measurement system / scale.
	Margin tare	Reset the zero point of the measurement system / scale.
	Gravity zone	Set the gravity zone of the scale for the region in which the device is being used.
	Currency	Perform calibration of bills or coins.

Setting	Description	Purpose
	Network	Set or adjust advanced network/ connectivity settings for the device, such as baud rate or ethernet network parameters (Cashmaster One Max only).
	Restore options	Restores the device settings back to factory default values. The options are Reset IDs, Restore Currency, Restore Switches and Restore all.

4.3 Editing the counter workflow

You can edit the counter workflow to enable or disable individual currencies and denominations. This may be useful if, for example, your business doesn't typically receive many high denomination bank bills, or if an older variant of bill (such as paper) is superseded by a newer variant (such as polymer).

1. On the Home screen, tap **Count Settings**.
2. Select the **Edit Workflow** option. 
3. Use the on-screen **Currency** and **Denomination** options to set each currency and denomination to one of the following options:
 - **Off** - The currency or denomination does not appear anywhere in the workflow.
 - **Manual** - The currency or denomination exists in the workflow, but is skipped during a normal count. To manually select the item during a cash count, use the currency selector or denomination selector.
 - **Auto** - The currency or denomination exists in the workflow and is used during a normal count.
4. Tap **Set**.

4.4 Recalibrating Container, Packaging and Non-Cash Items

Go to the Home screen and tap **Count Settings**. Then select **Calibrate**.

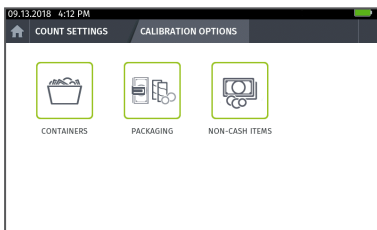

When you arrive at the **Calibration Options** screen, select container, packaging or non-cash items depending on your requirement. Follow on-screen instructions. Please note that you can manually modify the item weight where the keypad icon appears. 

4.5 Stored Counts (Max only)

The Cashmaster One Max supports counts from multiple tills.

1. On the **Home** screen, tap **Multi-count mode** .

2. Enter the **Till number**.

Other till identification information may be requested depending on how your counter is configured.

3. Tap **Set**.

4. Follow the normal count workflow.

For more information, see "Counting" on page 30.

5. Tap **Review**.

6. Tap **Finish** to end the cash count, or tap Save & New Till to count another till.

4.5.1 Viewing stored counts

1. From the Home screen, tap the Multi-count modes icon.

2. Tap the Stored Counts tab on the Information bar.

All stored counts are displayed within a scrollable list.

3. From the Stored Counts tab you can do the following:

- Print all - print the till counts.
- Transfer all - transfer all till counts over a remote connection (if configured).
- Delete all - delete all till counts.
- Review individual stored counts by tapping the blue  arrows.
- Print or transfer individual stored counts from within their Review screen.
- Select 'Grand Totals' to get totals of stored counts (Max Only).

4.6 Changing the printer roll

When the paper from the Cashmaster Printer One begins to show a red stripe, the printer roll is nearly empty and must be changed.

1. Remove the Cashmaster Printer One from the counter.
 - ▶ For more information, see Section 2.3 "Install the optional printer" on page 18
2. Press the release lever to the left of the print head.

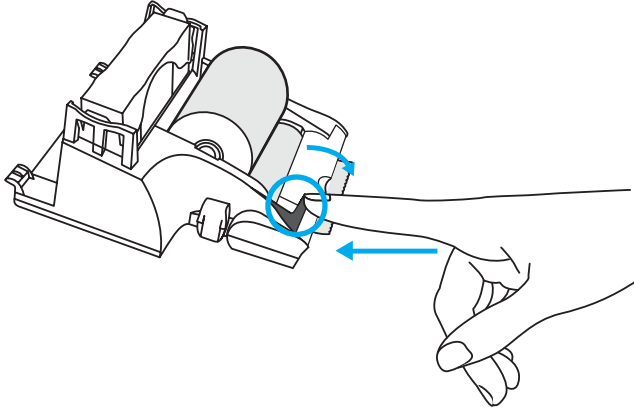

The print head releases and springs forward.

3. Replace the printer roll, paying attention to the orientation of the new roll when inserted.

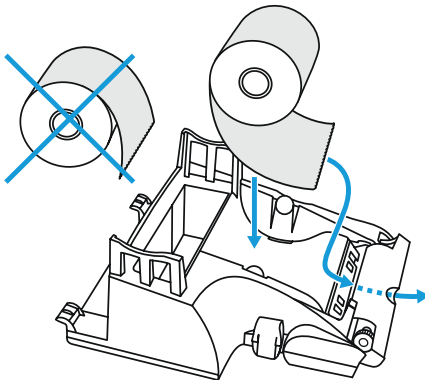

4. Feed the end of the printer roll through the print head.
5. Push the print head back into place until it engages with a click.

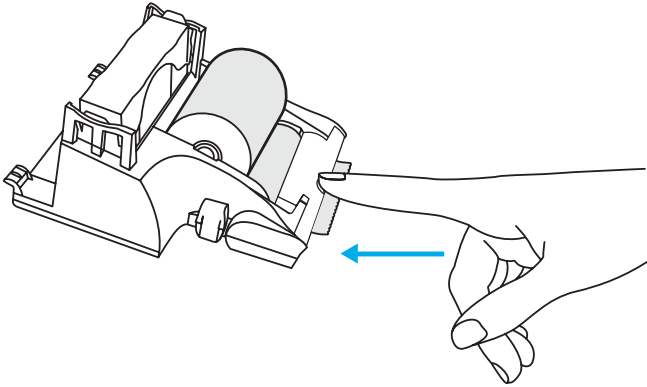

4.7 Removing the hod

To provide accurate count results, the hod must be kept clean. Remove the hod before cleaning it.

► For more information, see "Care and maintenance" on page 40

Notice *If the hod is damaged it must be replaced.*

To remove the hod from the counter, gently twist and pull the hod while holding down the counter.

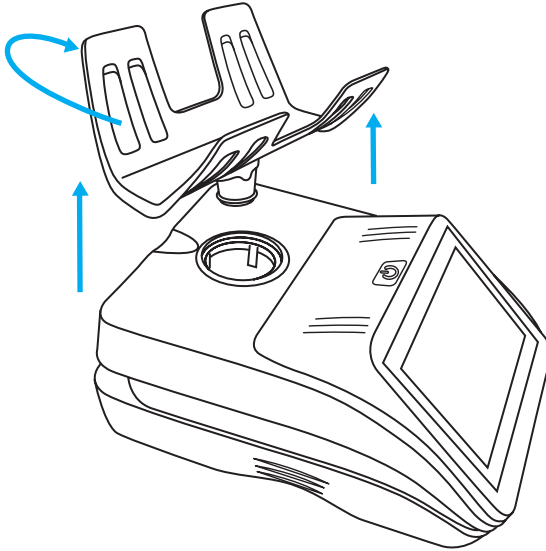

4.8 Care and maintenance

Ensure that the power is switched off when cleaning the Cashmaster One counter.

Clean the counter with a dry cloth only. Do not use any cleaning products or damp material.

Notice *Do not clean the hod while it is still attached to the counter.*

Notice *Do not leave any objects on the counter or hod when not in use.*

Notice *Do not spill any liquids on the counter. If liquid is spilled on the counter, disconnect the power immediately and contact your supplier.*

4.9 Re-setting your device

To re-set your device back to 'out of the box' status, please contact your local Cashmaster Customer Service Team.

5 Troubleshooting

This section provides troubleshooting information to resolve common issues.

5.1 Bills

Message	Mode	Description
Scale has lost its zero point	Loose bill counting	Your counter has drifted from its factory-calibrated zero weight, usually due to a draft or vibration. Ensure the hod is empty and press the power on/off button once. Tap Tare and follow the on-screen instructions.
Please remove the scoop/till cup	Loose bills counting	You have left the scoop or till cup on the hod while trying to count bills. Remove the scoop and continue with the counting workflow.
Too many, remove some	Loose bills counting	Bills should be counted in slices of no more than 30 bills at a time. Remove a few bills until the message is cleared and continue with the counting workflow. For more information, see Section 5.4 “ <i>Bill learning</i> ” on page 43.

5.2 Coins

Message	Mode	Description
Too much weight on scale	Any	Cashmaster One supports up to 1.5kg. Remove some of the coins.
Suspect	Packaged bills or coins	The measured weight of the item currently on the scale does not fall within the expected range for the current media type. Verify the correct denomination is selected on screen, and select the correct item if required. For packaged bills or coins, verify the correct quantity of items is included in the package that is being counted.

5.3 Printer

Error	Description
Printer not responding, but printer icon showing	Verify that the printer battery and paper are correctly inserted. Charge the scale and printer together using the supplied mains adaptor for a minimum of 1 hour. If the printer is still unresponsive, contact the Cashmaster helpline.
Poor printer output quality	Ensure that only Cashmaster International Ltd supplied printer thermal paper is fitted to your machine, and that it is correctly installed. For more information, see Section 4.5 “Changing the printer roll” on page 37. Charge the scale and printer together using the supplied mains adaptor for a minimum of 1 hour.
My printer is jammed	The printer paper is not scrolling correctly. Remove the paper roll, tear off the crumpled paper then replace the paper roll. Do not pull the paper through. This may damage the printer.

Error	Description
Print timeout	The printer has not been recognised by the counter. Check the printer is connected and the printer icon is shown in the status bar.

5.4 Bill learning

Bill weights vary slightly depending on age and usage, and this may cause occasional 'Too many, remove some' alerts.

All Cashmaster products include patented bill learning algorithms and can be trained with current bill weights to improve the 'slice limit'. This reduces the chance of a 'Too many, remove some' alert.

1. On the Count screen, select Loose Bills from the Media Type selector.
2. Choose the bill denomination you need to train.
3. Weigh individual bills to train the device with more accurate current bill weights.



Switch off Auto-Advance if you plan on adding and removing many bills of the same denomination to ensure that you remain on the chosen denomination until you manually select another.

5.5 Miscellaneous

Message	Description
High vibration lockout	The counter can no longer count media added to the hod. Check that the counter is placed on a level surface and away from vibrations and drafts, for example, air conditioning systems or fans.

Message	Description
Battery low	Attach the counter to the power supply. The battery charge status is shown in the status bar  .
Scale below minimum weight	The hod may not be fitted correctly. Ensure the hod is fitted correctly and has clicked into place.

If you continue to experience problems, please contact the Cashmaster helpline. The contact information for your local office can be found on page 47.

6 Specifications

This section details the specifications of the Cashmaster One counter.

6.1 Regulatory and approvals

- Electromagnetic Compatibility (EMC) Directive 2014/30/EU
- Restriction of Hazardous Substances (RoHS) Directive 2011/65/EU
RoHS 2
- Waste Electrical & Electronic Equipment (WEEE) Directive 2012/19/EU



6.2 Counter specifications

The Cashmaster One counters have the following technical specifications:

Weight	1.18kg (Including battery, hod, base plate cover)
Dimensions	160 x 216 x 168mm
Load capacity	1.5kg
Power supply	12VDC 2.5A (max)
Battery type	LiPo 7.4 V 2500mAH

Average battery charging time	6 hours For best results, charge at between 10°C/50°F and 30°C/86°F
--------------------------------------	--

6.3 Printer specifications

The Cashmaster Printer One has the following technical specifications:

Weight	0.34kg (Including battery)
Dimensions	116 x 134 x 66mm
Power supply	12VDC (From connection with Cashmaster One counter)
Battery type	LiPo 7.4 V 2500mAH
Average battery charging time	6 hours For best results, charge at between 10°C/50°F and 30°C/86°F

7 Global support

- **North America**
t: +1 877 227 4627
e: servicesusa@cashmaster.com
- **Hong Kong and Asia**
t: +852 2157 9363
e: enquiriesasia@cashmaster.com
- **Germany**
t: +49 (0) 2463 999 339
e: germany@cashmaster.com
- **UK and all other customers**
t: +44 (0) 1383 410 121
e: support@cashmaster.com



cashmaster.com